



■ QUICK SELECTION / Selezione veloce							input speed (n <sub>1</sub> ) = 1400 min <sup>-1</sup>								
Output Speed n <sub>2</sub> [min <sup>-1</sup> ]	Ratio i	Motor power P <sub>1M</sub> [kW]	Output torque M <sub>2M</sub> [Nm]	Service factor f.s.	Nominal power P <sub>1R</sub> [kW]	Nominal torque M <sub>2R</sub> [Nm]	Available B5 motor flanges				Available B14 motor flanges			Output Shaft Ø	Ratios code
							B	C	D	E	Q	R	T		
							63	71	80	90	71	80	90		
18.5	<b>75.50</b>	1.5	725	1.1	1.7	825	B				C	C		191318	01
16.2	<b>86.47</b>	1.5	830	1.1	1.6	900	B				C	C		191316	02
14.0	<b>100.22</b>	1.5	962	0.9	1.4	900	B				C	C		171316	03
12.0	<b>116.56</b>	1.1	817	1.1	1.2	900	B				C	C		171314	04
10.2	<b>136.82</b>	1.1	959	0.9	1.0	900	B				C	C		151314	05
9.1	<b>153.05</b>	0.75	736	1.1	0.83	810	B				C	C		190816	06
8.6	<b>163.31</b>	0.75	785	1.1	0.86	900	B				C	C		131314	07
7.9	<b>178.01</b>	0.75	856	1.1	0.79	900	B				C	C		190814	08
7.3	<b>191.67</b>	0.75	922	1.0	0.73	900	B				C	C		101316	09
6.8	<b>206.32</b>	0.75	992	0.9	0.68	900	B				C	C		170814	10
6.3	<b>222.92</b>	0.55	791	1.1	0.63	900	B				C	C		101314	11
5.8	<b>242.18</b>	0.55	859	1.0	0.58	900	B				C	C		150814	12
5.6	<b>250.15</b>	0.55	888	1.0	0.56	900	B				C	C		91316	13
4.8	<b>289.08</b>	0.55	1026	0.9	0.49	900	B				C	C		130814	14
4.2	<b>330.31</b>	0.37	783	1.1	0.42	890	B				C	C		71316	15
3.5	<b>394.59</b>	0.37	936	1.0	0.36	900	B				C	C		100814	16
2.7	<b>514.99</b>	0.25	824	1.1	0.27	900	B				C	C		90814	17
2.1	<b>680.03</b>	0.18	832	1.1	0.21	900	B				C	C		70814	18

The dynamic efficiency is **0.94** for all ratios

- Motor Flanges Available** Flange Motore Disponibili
- B) Supplied with Reduction Bushing** Fornito con Bussola di Riduzione
- Available on Request without reduction bushing** Disponibile a Richiesta senza Bussola di Riduzione
- C) Motor Flange Holes Position** Posizione Fori Flangia Motore

**EN** Unit FC73 is supplied without lubricant and equipped with a breather, level and drain plugs. User can add mineral oil keeping existing plugs. Should the user wish to fill it with synthetic oil, it is recommended to replace the existing plugs with a closed plug. See table 1 for lubrication and recommended quantity. In table 2 please see possible radial loads and axial loads on the gearbox.

H1	H4	H3	H2	H5	H6
3.55 LT	1.95 LT	1.95 LT	1.95 LT	3.75 LT	2.00 LT

**AGIP** Blasias 460

For all details on lubrication and plugs check our website **tab. 1**  
Per maggiori dettagli su lubrificazione e tappi olio vedi il nostro sito web

**I** Il riduttore tipo FC73 è fornito privo di lubrificazione con tappi di sfiato, livello e scarico olio. L'utente può immettere olio minerale mantenendo i tappi esistenti. Se immetterà olio sintetico, dovrà sostituire i tappi esistenti con altri tipo chiuso. Tab.1 per oli e quantità consigliati. Tab.2 carichi radiali e assiali applicabili al riduttore.

**D** Das Getriebe der Baugröße FC73 wird ohne Schmiermittel geliefert. Es ist jedoch mit Einfüllschraube, Überdruckventil und Ablaßschraube ausgerüstet. Das benötigte mineralische Öl kann über die Einfüllschraube eingefüllt werden. Sollte synthetisches Öl bevorzugt werden, so ist sind das eingebaute Überdruckventil durch eine geschlossenen Schraube zu ersetzen. In Tabelle 1 ist die Schmiermenge und das empfohlene Schmiermittel angegeben. In Tabelle 2 sind die zulässigen Radial - und Axialbelastungen des Getriebes aufgeführt.

**F** Le réducteur de type FC73 est fourni sans lubrification et avec un bouchon de remplissage, de niveau et d'évacuation de l'huile. L'utilisateur peut y verser de l'huile minérale en conservant les bouchons existants. S'il y versera de l'huile synthétique, il devra substituer les bouchons existants avec d'autres bouchons de type fermé. Voir tableau 1 concernant les huiles et les quantités conseillées. Voir tableau 2 concernant les charges radiales et axiales applicables au réducteur

**E** El reductor tamaño FC73 se suministra sin lubricante, provisto de tapones de respiración, nivel y descarga de aceite. El usuario puede utilizar aceite mineral, manteniendo los tapones existentes. Si prefiere utilizar aceite sintético deberá sustituir los tapones existentes por tapones ciegos. La prerreducción se suministra con tapones ciegos, lubricado de por vida con aceite sintético. Ver tabla 1, para cantidades y aceites recomendados. En la tabla 2, se encuentran las cargas radiales y axiales admitidas por el reductor.

### RADIAL AND AXIAL LOADS

**Output shaft**  
Albero di uscita

$F_{eq} = F_R \cdot 174.5 \cdot X + 134.5$

n <sub>2</sub>	FA	FR	n <sub>2</sub>	FA	FR	n <sub>2</sub>	FA	FR
300	740	3700	140	860	4300	70	1020	5100
250	800	4000	120	900	4500	40	1300	6500
200	830	4150	85	970	4850	15	1700	8500

**On request reinforced bearings to increase loads.**  
A richiesta cuscinetti rinforzati per aumentare i carichi.

**Input shaft**  
Albero in entrata

n <sub>1</sub>	FA	FR
1400	400	2000
900	440	2200
500	440	2200

**tab. 2**

**PFC73C...** Basic gearbox  
Riduttore base

Gearbox weight  
peso riduttore **30.5 kg**

M. flanges	Kit code	øF	A
63B5	K063.4.041	140	250.5
71B5	K063.4.042	160	248.5
80/90B5	K063.4.043	200	250.5
71B14	K063.4.047	105	248.5
80B14	K063.4.046	120	250.5
90B14	K063.4.041	140	250.5

● Available torque arms,  
see our web site  
Bracci di reazione disponibili,  
consulta il nostro sito web

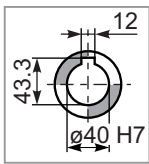

**Standard**  
Hollow shaft

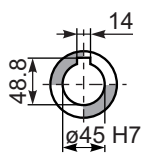

**On request**  
A richiesta

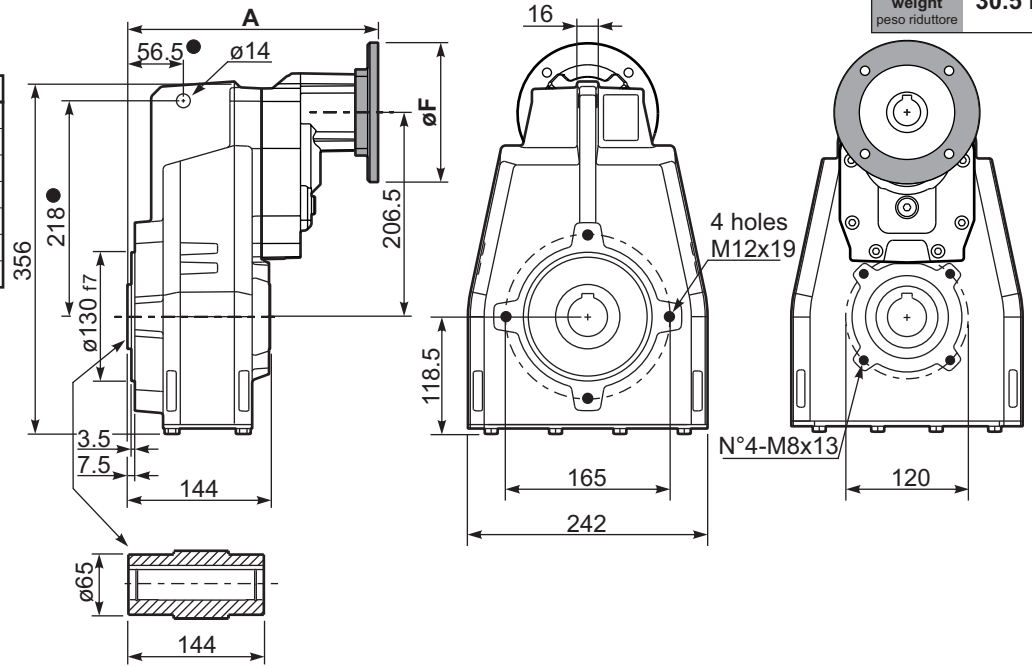

**PFC73...-F...** Output flange  
Flangia uscita

M. flanges	k1
63B5	283
71B5	281
80/90B5	283
71B14	281
80B14	282
90B14	283

Available output flanges  
Flange di uscita

a1 ø	b1	c1	e1	f1	s1	Kit code
250	180	13	215	3	14	KF70.9.011
300	230	16	265	4	14	KF70.9.012
350	250	18	300	4	18	KF70.9.013

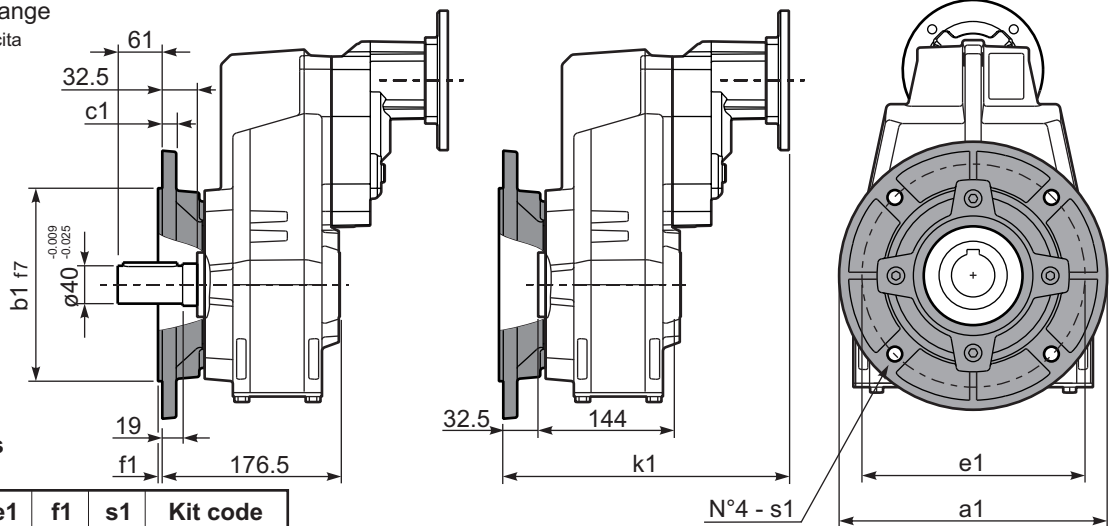

**RFC73C...** Input Shaft  
Albero in entrata

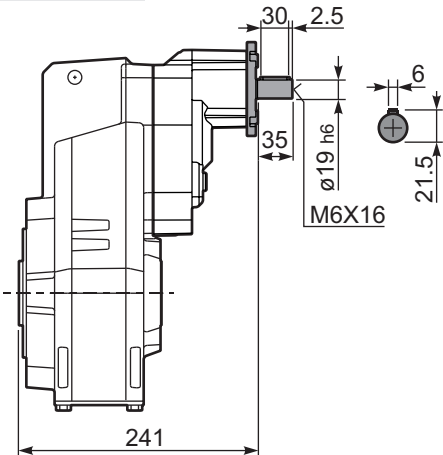

**PFC73 A...** Single output shaft  
Albero uscita semplice

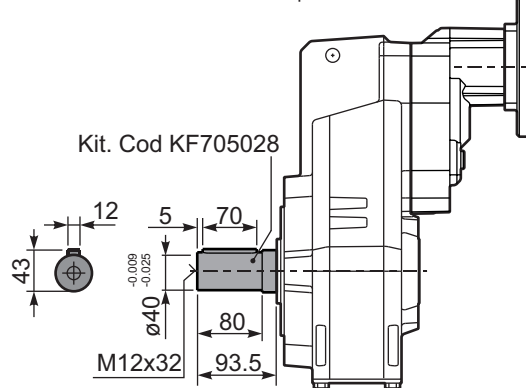

**PFC73D...** Shrink disk  
Calettatore

