



#### QUICK SELECTION / Selezione veloce

input speed ( $n_1$ ) = 1400 min<sup>-1</sup>

Output Speed $n_2$ [min <sup>-1</sup> ]	Ratio $i$	Motor power $P_{1M}$ [kW]	Output torque $M_{2M}$ [Nm]	Service factor f.s.	Nominal power $P_{1R}$ [kW]	Nominal torque $M_{2R}$ [Nm]	Available B5 motor flanges		Available B14 motor flanges			Output Shaft 	Ratios code	
							B	C	O	P	Q			
							63	71	56	63	71			
29.3	<b>47.70</b>	1.1	334	1.4	1.6	480			C	C		281316	standard ø30  On request ø35	01
16.2	<b>86.27</b>	0.75	415	1.2	0.87	480			C	C		191316		02
14.0	<b>100.00</b>	0.75	481	1.0	0.75	480			C	C		171316		03
11.9	<b>117.38</b>	0.55	416	1.2	0.64	480			C	C		151316		04
10.0	<b>140.10</b>	0.55	497	1.0	0.53	480			C	C		131316		05
7.3	<b>191.24</b>	0.37	454	1.1	0.39	480			C	C		101316		06
5.6	<b>249.59</b>	0.25	399	1.2	0.30	480			C	C		91316		07
4.2	<b>329.58</b>	0.25	527	0.9	0.23	480			C	C		71316		08

The dynamic efficiency is **0.94** for all ratios

**A** Motor Flanges Available  
Flange Motore Disponibili

**B** Supplied with Reduction Bushing  
Fornito con Bussola di Riduzione

**B** Available on Request without reduction bushing  
Disponibile a Richiesta senza Bussola di Riduzione

**C** Motor Flange Holes Position  
Posizione Fori Flangia Motore

**EN** Unit **FS50** is supplied with synthetic oil for lifetime lubrication, no maintenance is necessary. See table 1 for lubrication and recommended quantity. In table 2 please see possible radial loads and axial loads on the gearbox.

**I** Il riduttore **FS50** viene fornito completo di olio sintetico per la lubrificazione permanente e non necessita di alcuna manutenzione. Vedi tab.1 per oli e quantità consigliati. In tab.2 sono presenti i carichi radiali e assiali applicabili al riduttore.

**D** Das Getriebe **FS50** ist mit synthetischem Öl gefüllt und ist lebensdauergeschmiert. In Tabelle 1 ist die Schmiermenge und das empfohlene Schmiermittel angegeben. In Tabelle 2 sind die zulässigen Radial- und Axialbelastungen des Getriebes aufgeführt.

**F** Le réducteur **FS50** est fourni complet avec de l'huile synthétique pour la lubrification permanente et ne nécessite aucun entretien. Voir tableau 1 concernant les huiles et les quantités conseillées. Les charges radiales et axiales applicables au réducteur sont précisées dans le tableau 2.

**E** El reductor tamaño **FS50** se suministra, lubricado de por vida con aceite sintético y no requieren mantenimiento alguna. Ver tabla 1, para cantidades y aceites recomendados. En la tabla 2, se encuentran las cargas radiales y axiales admitidas por el reductor.

Standard supplied	For these mounting position specify in the order or add oil Per queste posizioni specificare in fase d'ordine o aggiungere olio				
H1	H4	H3	H2	H5	H6
0.95 LT	0.50 LT	0.50 LT	0.70 LT	0.95 LT	0.95 LT
AGIP Telium VSF 320			SHELL Omala S4 WE 320		

For all details on lubrication and plugs check our website **tab. 1**  
Per maggiori dettagli su lubrificazione e tappi olio vedi il nostro sito web

#### RADIAL AND AXIAL LOADS

Input shaft Albero in entrata	$F_R$ (N)	$F_A$ (N)	$n_1$	FA	FR
	↓ $F_R$ (N)	← $F_A$ (N) SX DX (*)	1400	140	700
			900	160	800

\*Strong axial loads in the DX direction are not allowed.  
Non sono consentiti forti carichi assiali con direzione DX

**tab. 2**

# Compact gear 480Nm FS50

**P**FS50C... Basic gearbox  
Riduttore base

Gearbox weight  
peso riduttore **11.5 kg**

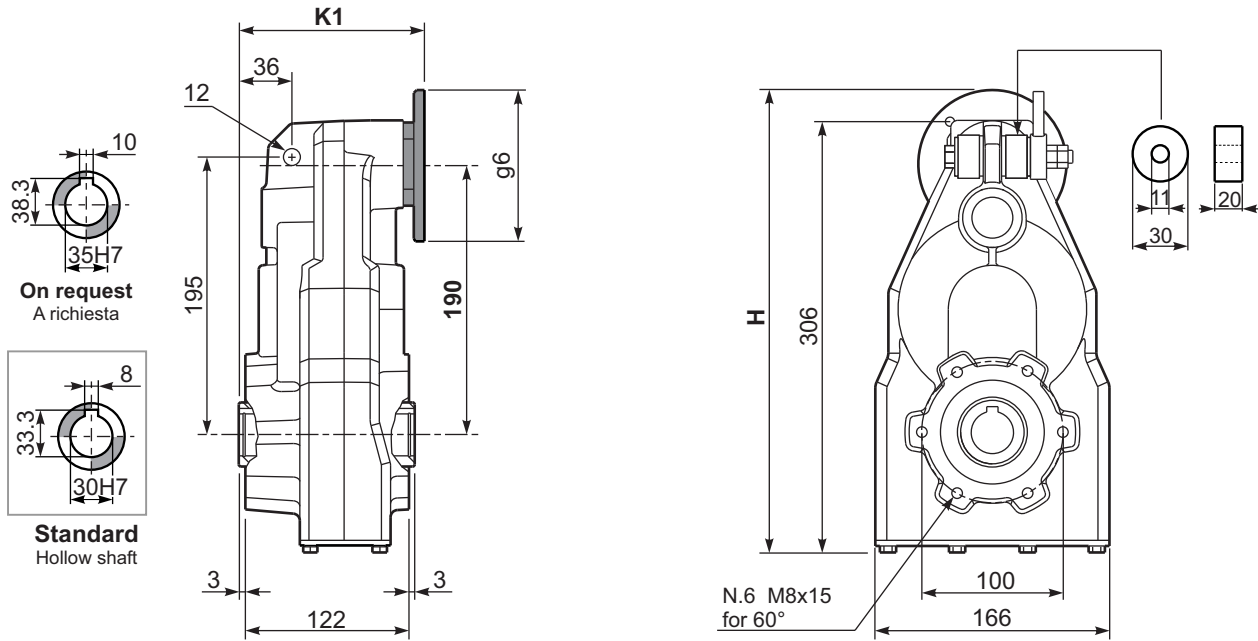

B14 Motor Flanges	H	g6	k1	kit code
56 B14	314	80	130.5	KC40.4.049
63 B14	320	90	133	K050.4.047
71 B14	328	105	130.5	K050.4.045

B5 Motor Flanges	H	g6	k1	kit code
63 B5	345	140	133	K050.4.041
71 B5	355	160	130.5	K050.4.042

**R**FS50C... Input shaft  
Albero in entrata

