

#### QUICK SELECTION / Selezione veloce

input speed ( $n_1$ ) = 1400 min<sup>-1</sup>

Output Speed $n_2$ [min <sup>-1</sup> ]	Ratio $i$	Motor power $P_{1M}$ [kW]	Output torque $M_{2M}$ [Nm]	Service factor f.s.	Nominal power $P_{1R}$ [kW]	Nominal torque $M_{2R}$ [Nm]	Available B5 motor flanges		Available B14 motor flanges			Dynamic efficiency <b>RD</b>	Tooth Module [mm]	Ratios code 
							B	C	O	P	Q			
							63	71	56	63	71			
10	<b>140</b>	0.37	205	1.8	<b>0.66</b>	<b>368</b>	<b>B</b>		B-C	B-C		58	4.5	01
7.1	<b>196</b>	0.37	257	1.4	<b>0.53</b>	<b>368</b>	<b>B</b>		B-C	B-C		52	4.7	02
5.0	<b>280</b>	0.37	332	1.6	<b>0.58</b>	<b>518</b>	<b>B</b>		B-C	B-C		47	4.7	03
3.6	<b>392</b>	0.37	435	1.2	<b>0.44</b>	<b>518</b>	<b>B</b>		B-C	B-C		44	4.7	04
2.4	<b>588</b>	0.25	371	1.4	<b>0.35</b>	<b>518</b>	<b>B</b>		B-C	B-C		37	4.7	05
1.8	<b>784</b>	0.25	455	1.1	<b>0.28</b>	<b>518</b>	<b>B</b>		B-C	B-C		34	4.7	06
1.4	<b>1036</b>	0.18	420	1.2	<b>0.22</b>	<b>518</b>	<b>B</b>		B-C	B-C		33	4.7	07
1.1	<b>1288</b>	0.18	474	1.1	<b>0.20</b>	<b>518</b>	<b>B</b>		B-C	B-C		30	4.7	08
0.7	<b>1960</b>	0.12	449	1.2	<b>0.14</b>	<b>518</b>	<b>B</b>		B-C	B-C		28	4.7	09
0.5	<b>2856</b>	0.12	584	0.9	<b>0.11</b>	<b>518</b>	<b>B</b>		B-C	B-C		25	4.7	10

**A** Motor Flanges Available  
Flange Motore Disponibili

**B** Supplied with Reduction Bushing  
Fornito con Bussola di Riduzione

**B** Available on Request without reduction bushing  
Disponibile a Richiesta senza Bussola di Riduzione

**C** Motor Flange Holes Position  
Posizione Fori Flangia Motore

**EN** Unit **854** is supplied with synthetic oil, providing "long life" lubrication. For mounting position V5-V6 please contact us. See table 1 for lubrication and recommended quantity. In table 2 please see possible radial loads and axial loads on the gearbox.

**I** Il riduttore tipo **854** viene fornito lubrificato a vita con olio sintetico. Per posizioni V5-V6 contattare il ns. servizio tecnico. Vedi tab.1 per oli e quantità consigliati. In tab.2 sono presenti i carichi radiali e assiali applicabili al riduttore.

**D** Für die Lebensdauerschmierung ist das Getriebe der Größe **854** mit synthetischem Öl befüllt. Bei Einbaulage V5 oder V6 bitten wir um Rücksprache. In Tabelle 1 ist die Schmiermenge und das empfohlene Schmiermittel angegeben. In Tabelle 2 sind die zulässigen Radial- und Axialbelastungen des Getriebes aufgeführt.

**F** Le réducteur de type **854** est fourni lubrifié à vie avec de l'huile synthétique. Concernant les positions V5.V6, contactez notre service d'assistance technique. Voir tableau 1 concernant les huiles et les quantités conseillées. Les charges radiales et axiales applicables au réducteur sont précisées dans le tableau 2.

**E** El reductor tamaño **854** se suministra, lubricado de por vida con aceite sintético. Para las posiciones V5 y V6 contactar con nuestro servicio técnico. Ver tabla 1, para cantidades y aceites recomendados. En la tabla 2, se encuentran las cargas radiales y axiales admitidas por el reductor.

**LUBRICATION 854 Oil** **1.2 Lt.**

**Quantity 1.2/0.09 Lt.**

**AGIP** Telium VSF 320

**SHELL** Omala S4 WE 320

For all details on lubrication and plugs check our website **tab. 1**  
Per maggiori dettagli su lubrificazione e tappi olio vedi il nostro sito web

#### RADIAL AND AXIAL LOADS

##### Output shaft

Albero di uscita

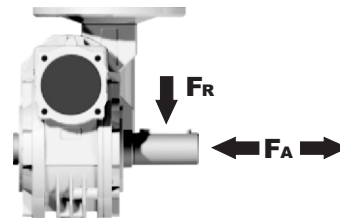

$n_2$ [min <sup>-1</sup> ]	FA [N]	FR [N]
<b>25</b>	1000	5000
<b>15</b>	1160	5800

##### Input shaft

albero in entrata

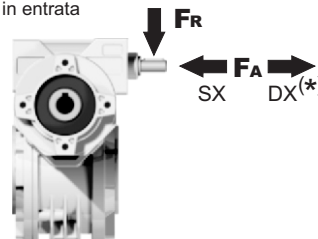

$n_1$ [min <sup>-1</sup> ]	FA [N]	FR [N]
<b>1400</b>	42	210

**\*Strong axial loads in the DX direction are not allowed.**  
Non sono consentiti forti carichi assiali con direzione DX

**tab. 2**

3D dimensions on request

**P854FB...** Basic wormbox  
Riduttore base

M. flanges	Kit code	øF	A
63B5	K050.4.041	138	74
71B5	K050.4.042	160	71.5
56B14	KC40.4.049	80	71.5
63B14	K050.4.047	90	74
71B14	K050.4.045	105	71.5

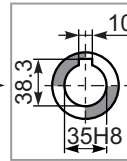
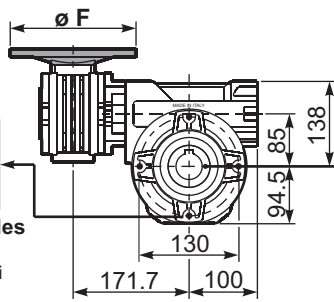
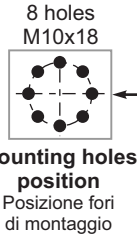
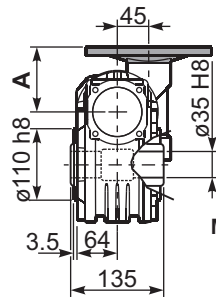

Standard  
Hollow shaft

Gearbox weight  
peso riduttore **19.50 kg**

**P854PA...** Feet  
Piedini

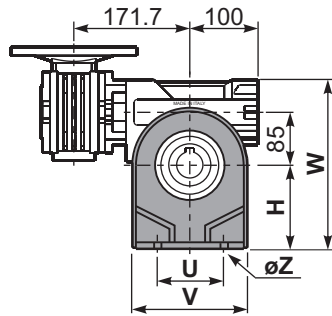
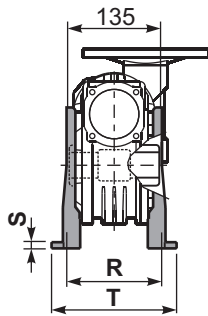

**P854PB...** Feet  
Piedini

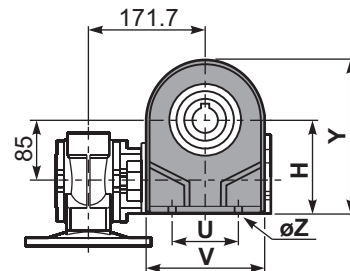

**P854PV...** Feet  
Piedini

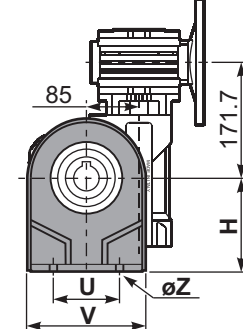

	H	R	S	T	U	V	Y	W	øZ	kit code
type B	142	145	5	182	140	180	236.5	280	ø10.5	K085.9.022
type S	-	-	-	-	-	-	-	-	-	-

**P854FC...** Output flange  
Flangia uscita

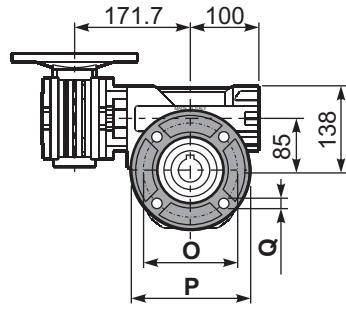
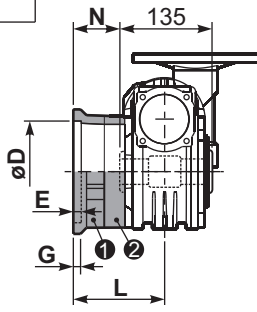

**P854BR...** Reaction arm  
Braccio di reazione

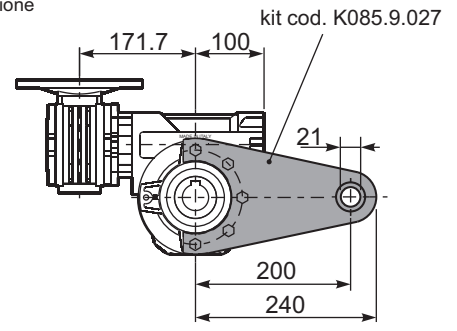
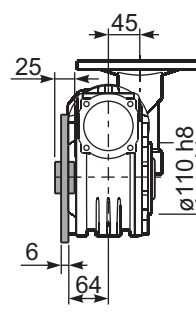

type B	øD	E	G	L	N	O	P	Q	kit code
FC	152 <sup>+0.06</sup> / <sub>+0.00</sub>	5	16	108	40.5	176	205	13	1, 2 K085.9.010
FL	152 <sup>+0.06</sup> / <sub>+0.00</sub>	5	16	148.5	81	176	205	13	1, 2 K085.9.010 2 K085.0.201

type S	øD	E	G	L	N	O	P	Q	kit code
F1	130 <sup>+0.040</sup> / <sub>0</sub>	5	13	117.5	50	165	200	11.5	1, 2 KS085.9.012
F2	152 <sup>+0.06</sup> / <sub>0</sub>	5	15	147.5	80	180	205	12.5	1, 2 KS085.9.013
F4	130 <sup>+0.040</sup> / <sub>0</sub>	5	13	106.5	39	165	200	13	1, 2 KS085.9.015

**P854.....S...** Single Shaft  
Albero lento semplice

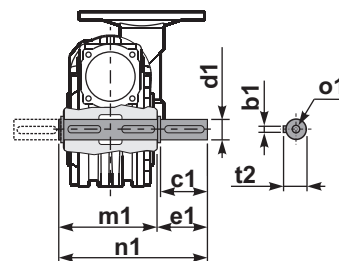

**P854.....D...** Double Shaft  
Albero lento bisp.

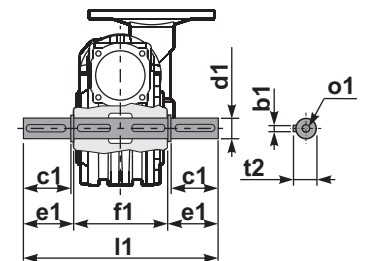

1 kit cod. K085.5.028 type B

2 kit cod. K085.5.029 type B

**R854FB...** Input shaft  
Albero in entrata

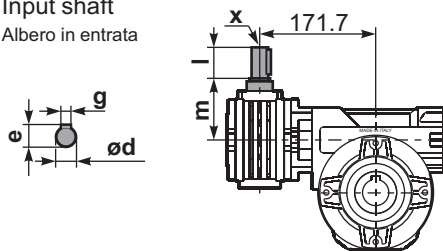

	ød	e	g	l	m	x	kit code
type B	11 h6	12.5	4	30	68	-	1, 2 K045.5.006 PAM71
type S	-	-	-	-	-	-	1, 2 -

	b1	c1	d1	e1	f1	l1	m1	n1	t2	o1
type B	10	60	35 <sup>-0.005</sup> / <sub>-0.020</sub>	73.5	135	282	141	214.5	38	M10x23
type S	-	-	-	-	-	-	-	-	-	-